

TECHNICAL SPECIFICATIONS

Wedgeloek Multi-Model® Coupler with I-Lock™ Safety System

Wedgeloek Weight Class	Excavator Machine Weight	Part Number	Weight (est)	Coupler Base Pin Centers (min/max)	Base Width	Pin ø	Max Operating Pressure	SWL (Lifting Eye)
	Tonnes (lbs)		Kgs (lbs)					
130	10.0-13.0T (22000-29000)	CMI-130-060-065	195 (429)	355 / 420 (13.9 / 16.5)	218 (8.6)	60/65	260 (3750)	6500 (14300)
170	14.0-17.0T (30800-38000)	CMI-170-070	310 (682)	400 / 465 (15.7 / 18.3)	280 (11.0)	70	260 (3750)	6500 (14300)
170	14.0-17.0T (30800-38000)	CMI-170-080	310 (682)	390 / 435 (15.3 / 17.1)	300 (11.8)	80	260 (3750)	6500 (14300)
210	18.0-21.0T (39600-46200)	CMI-210-080	310 (682)	430 / 485 (16.9 / 19.1)	300 (11.8)	80	260 (3750)	6500 (14300)
270	22.0-27.0T (48400-59400)	CMI-270-080	400 (880)	440 / 512 (17.3 / 20.1)	300 (11.8)	80	260 (3750)	12000 (26400)
270	22.0-27.0T (48400-59400)	CMI-270-090	400 (880)	495 / 520 (18.1 / 20.5)	325 (12.8)	90	260 (3750)	12000 (26400)
320	28.0-32.0T (61600-79200)	CMI-320-090 (a)	525 (1155)	495 / 570 (19.5 / 22.4)	345 (13.6)	90	260 (3750)	12000 (26400)
320	28.0-32.0T (61600-79200)	CMI-320-090 (b)	525 (1155)	460 / 520 (18.1 / 20.5)	325 (12.8)	90	260 (3750)	12000 (26400)
320	28.0-32.0T (61600-79200)	CMI-320-100	525 (1155)	525 / 590 (20.7 / 23.2)	370 (14.6)	100	260 (3750)	12000 (26400)
450	36.0-45.0T (80000-99000)	CMI-450-100	650 (1430)	570 / 635 (22.4 / 25.0)	424 (16.7)	100	260 (3750)	12000 (26400)
450	36.0-45.0T (80000-99000)	CMI-450-100-110	680 (1496)	540 / 630 (21.2 / 24.8)	399 (15.7)	100/110	260 (3750)	13500 (29700)

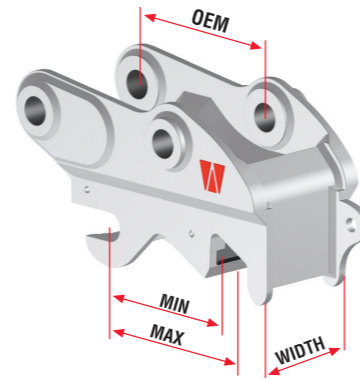

Wedgeloek OEM Custom Fit™ Coupler with I-Lock™ Safety System

Wedgeloek Weight Class	Excavator Machine Weight	Part Number	Weight (est)	Coupler Base Pin Centers & Width	Pin ø	Max Operating Pressure	SWL (Lifting Eye)
	Tonnes (lbs)		Kgs (lbs)	mm (in)			Bar (psi)
130	10.0-13.0T (22000-29000)	CSI-130	195 (429)	OEM Custom Fit	60/65	260 (3750)	6500 (14300)
170	14.0-17.0T (30800-38000)	CSI-170	310 (682)	OEM Custom Fit	70/80	260 (3750)	6500 (14300)
210	18.0-21.0T (39600-46200)	CSI-210	310 (682)	OEM Custom Fit	80	260 (3750)	6500 (14300)
270	22.0-27.0T (48400-59400)	CSI-270	400 (880)	OEM Custom Fit	80/90	260 (3750)	12000 (26400)
320	28.0-32.0T (61600-79200)	CSI-320	525 (1155)	OEM Custom Fit	90/100	260 (3750)	12000 (26400)
450	36.0-45.0T (80000-99000)	CSI-450	650 (1430)	OEM Custom Fit	100/110	260 (3750)	12000 (26400)
650	50.0-65.0T (110000-143000)	CSI-650	940 (2070)	OEM Custom Fit	> 115	260 (3750)	13500 (29700)
750	65.0-75.0T (143000-165000)	CSI-750	1130 (2490)	OEM Custom Fit	> 120	260 (3750)	13500 (29700)
1000	75.0-100.0T (165000-220000)	CSI-1000	1380 (3040)	OEM Custom Fit	> 130	260 (3750)	TBA

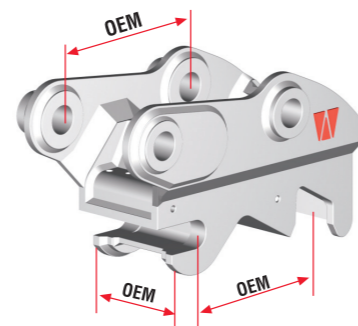

¹ Wedgeloek Multi-Model® Couplers are designed to pick up a wide range of attachments within the same weight class. Due to the vast array of bucket designs and the concept of Multi Model Compatibility, Wedgeloek will not be held responsible for coupler-to-bucket interference or misfit. If unsure, contact your nearest Wedgeloek dealer for clarification and specifications.
² Wedgeloek OEM Custom Fit™ Couplers are designed to accommodate either OEM or Custom Specifications.
 * SWL - Safe working load that can be suspended from the certified lifting eye on the coupler.
 * Specifications subject to change without notice.

Authorized Sales Representative:

10902

I-LOCK™ COUPLER by WEDGELOCK

Instant, Independent and Innovative Safety System

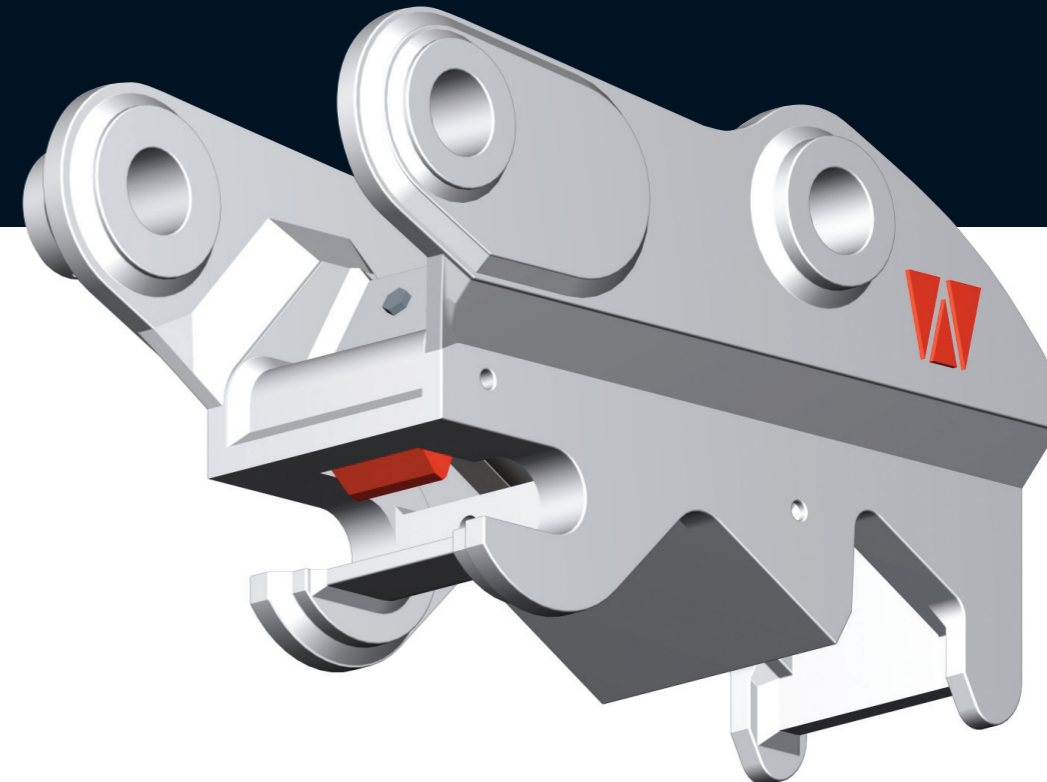

Introducing the I-Lock™ Coupler for excavators – the world's first coupler incorporating a fully independent safety system.

The "Instant, Independent and Innovative Safety System" or I-Lock™ is the ultimate "secondary lock safety system" for excavator couplers available globally today.

Designed for maximum operator safety, the I-Lock™ delivers the following key benefits:

- **INSTANT** – automatically secures the attachment to the coupler the instant the front jaw comes into contact with the front attachment pin. This instant connection eliminates the risk of losing control of the bucket or attachment during the "high risk" latching operation.
- **INDEPENDENT** – when the operator wants to change attachments, the primary wedge can be released first, the attachment placed in a safe position to disconnect and THEN the Safety Knuckle can be released. The operator has full, INDEPENDENT control.
- **INNOVATIVE** – the I-Lock™ Coupler is an innovative advancement in coupler safety. No other coupler in the world has a fully independent and instant safety-locking feature that is controlled by the operator.
- The **TIME-OUT** feature on the electronic switch ensures that even if the operator does not release the attachment in the time allowed, the Safety Knuckle will automatically re-engage to the safe position.

* Patents Pending



WEDGELOCK EQUIPMENT INC.
 1472 Linda Way, Sparks, NV 89431-6151, United States
 Toll-free: (888) 418-3311 Telephone: (775) 284-8262 Email: usinfo@wedgeloek.com

WEDGELOCK EQUIPMENT LTD
 72 Montgomery Crescent, Upper Hutt 5018, New Zealand
 Toll-free: 0800 424 482 Telephone: +64 4 526 3901 Email: nzinfo@wedgeloek.com



FEATURES OF THE I-LOCK™

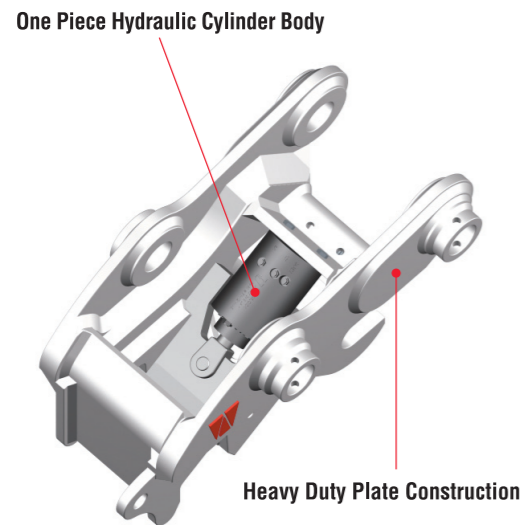
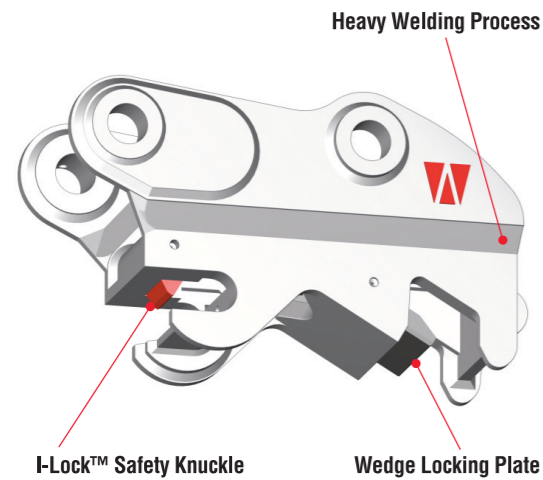

Available in two configurations – **Wedgelock Multi-Model®** and **Wedgelock OEM Custom Fit™** – the I-LOCK™ is packed with features:

- It is the world's first fully independent safety system.
- It incorporates the proven “Wedge Locking Principle” for the primary lock – used in all Wedgelock Couplers sold worldwide.
- The coupler body is constructed from Heavy Duty plate – using high and medium tensile materials for durability, longevity and high performance with less down time. The welding process developed and perfected by Wedgelock over many years is the heaviest utilized in the coupler business today.
- The world's only “one piece construction” hydraulic cylinder body for couplers eliminating port welding and potential feeder tube damage.
- The Double Acting Cylinder also has a “Pilot Operated Safety Check Valve” and two port options for ease of hose routing and pressure testing.
- The **Wedgelock Multi-Model®** with I-LOCK™ is available for machines from the 10t to 50t (22,000 Lbs to 110,000 Lbs) weight class and enables operators to connect to any attachment within the same weight class without having to modify existing buckets or attachments.¹
- The **Wedgelock OEM Custom Fit™** with I-LOCK™ is available for operators that require OEM fitment of their attachments to their coupler; the carrier machine can be either the same as the attachments or different. This feature is available for machines from the 10t to 100t (22,000 Lbs to 220,000Lbs) weight class.²

^{1,2}: See back page

HERE'S HOW THE I-LOCK™ WORKS

Connection:

Step 1: The I-LOCK™ Coupler has been designed to ensure that operators and co-workers can work within an environment that is safe from the potential hazards of changing buckets or attachments.

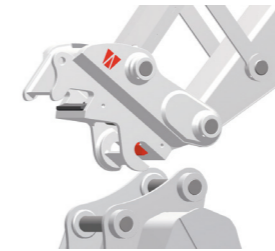

I-LOCK™ Coupler ready to engage

Step 2: The Safety Knuckle “INSTANTLY” latches over the attachment pin as soon as the operator engages the front jaw of the coupler. This automatic function removes the high risk of dropping an attachment during the changeover process.

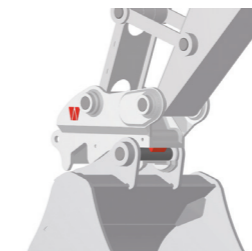

I-LOCK™ connected to first pin

Step 3: Once the operator has the Safety Knuckle engaged over the first pin, the attachment can be raised and the coupler crowded to the fully seated position. The Wedge Locking Plate is then activated by the electronic switch inside the cab to lock the coupler fully to the attachment.

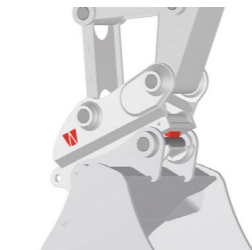

I-LOCK™ Coupler fully connected

Disconnection:

Step 1: To release the attachment the Wedge Locking Plate is disengaged first, leaving the Safety Knuckle fully latched and the attachment secured to the coupler.

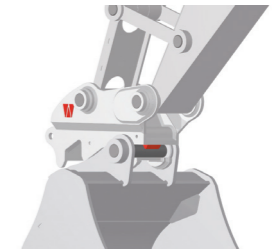

Primary Wedge retracted with Safety Knuckle still fully latched

Step 2: When the operator is satisfied that the attachment is in a safe environment to be released, the operator moves the electronic switch to the “un-lock safety” position. This operation activates the mechanism to raise the Safety Knuckle.

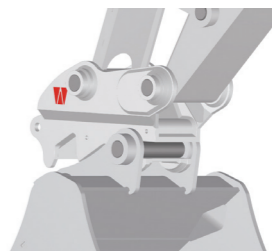

I-LOCK™ Safety Knuckle retracted remotely by operator

Step 3: As soon as the Safety Knuckle has been retracted the operator can safely move the I-LOCK™ Coupler away from the attachment pin fully disengaging the attachment from the coupler.

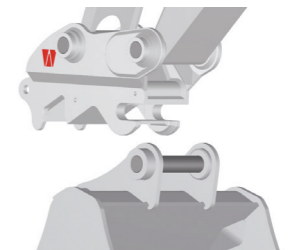

Operator moves I-LOCK™ Coupler away from attachment

Ready to Re-connect: After 5 seconds the Safety Knuckle will automatically reset to the SAFE position and the I-LOCK™ Coupler is ready to re-connect to another attachment.

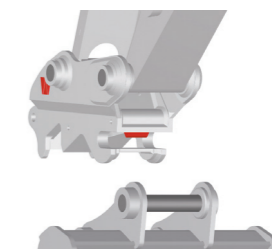

I-LOCK™ Coupler is ready to connect to an attachment with the Safety Knuckle in the DOWN position